

The Smart Bar LS800 Liquor Delivery Rail (LDR) supplies liquor, Wine, or Mixers to your Smartender Automated Cocktail Dispenser. Ideal for both FOH and BOH applications, the LDR is designed to be installed in the most confined spaces. The LDR can be placed anywhere that meets the minimum required dimensions.

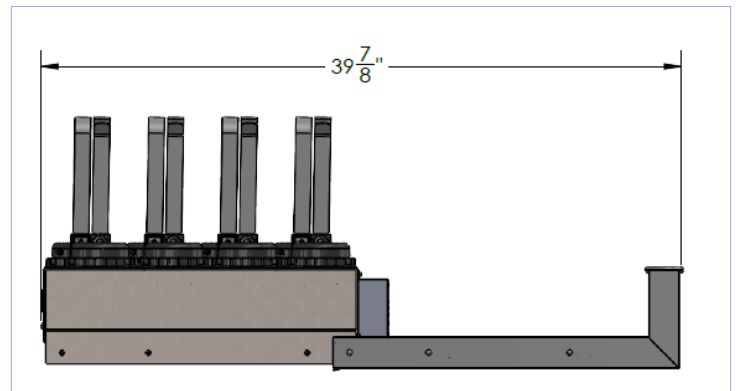
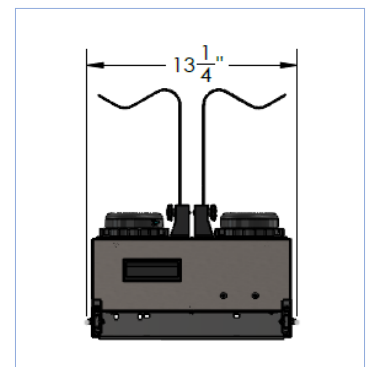
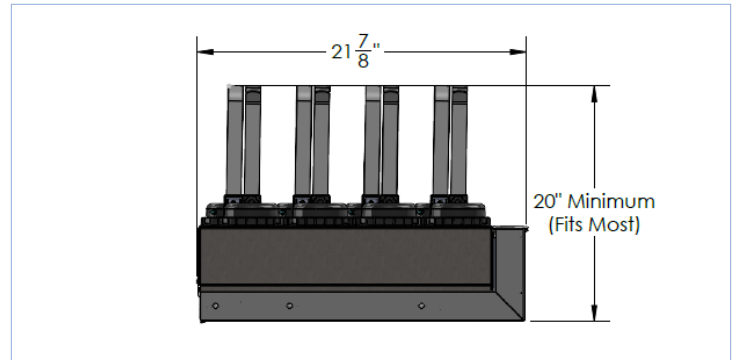

Features and Benefits

Slide out design and spill resistant bottle caps for easy bottle replacement.

Compact design for space constrained areas.

Compatible with the Smart Bar bottle Empty System on Select Smartender models.

Technical Specifications

| | |
|-----------------|---|
| Liquor Capacity | 8 brands, 1 bottle per |
| Safety | ETL Sanitation, ETL Safety |
| Material | Polymeric |
| Weight | 41 Pounds (each, no products installed) |



Intertek

1(866)399-7160
CONTACT@SMARTBARUSA.COM

WWW.SMARTBARUSA.COM